

FLOWTHRU PRO™

## NEXT GENERATION INTEGRATED ALUMINIUM THRESHOLD DRAIN

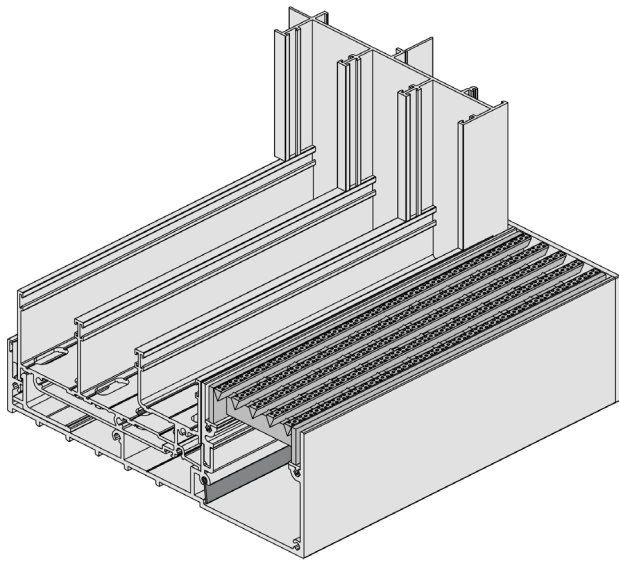

### KEY FEATURES

- FlowTHRU Pro™ delivers a single level set down, flush threshold drainage solution for a selection of Vantage® and Elevate™ Sliding Door Systems
- Single level set down reduces installation time and does not weaken the slab.
- A flush sill threshold allows internal and external floor surfaces to have the same finish level with no elevated threshold to create a trip hazard or interrupt the space.
- Choose from three grate options to suit your project. Aluminium, Stainless Steel or a Custom Tile insert to compliment existing flooring.
- Stainless Steel grate option features an anti-slip surface, complying with AS 4586 for slip resistance.
- Colour match your project - Aluminium grate is available in a variety of powder coat colours as well as clear anodised.
- Ideal for multi storey or suspended slab residential projects where a shallow rebate is required.

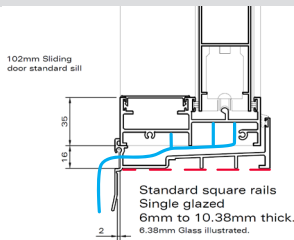

Single level set down allows outstanding drainage and fast, easy installation

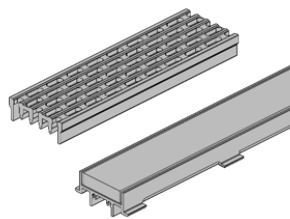

3 grate options

- Stainless Steel (Anti-Slip AS4586 compliant)
- Aluminium (powdercoat or anodise)
- Tile Insert



FlowTHRU Pro™ is the only drain system tested for use with Vantage® and Elevate™ Door systems.

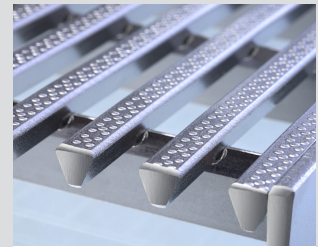

Stainless Steel insert features an anti-slip surface, complying with AS 4586 for slip resistance.

### COMPATIBLE WITH

#### VANTAGE WINDOWS & DOORS (UP TO 3 TRACKS WIDE)

Series 758 Sliding Door

Series 759 ComfortEDGE™ Sliding Door

#### ELEVATE ALUMINIUM SYSTEMS

Series 704 SlideMASTER™ Sliding Door

Series 704B SlideMASTER™ Sliding Door

Series 704FTH SlideMASTER™ Sliding Door

Series 704FBR SlideMASTER™ Sliding Door

Series 704T SlideMASTER™ Sliding Door

Series 704LS SlideMASTER™ Sliding Door

Series 704R SlideMASTER™ Sliding Door



specifyaws.com.au